

THE SNEEZEGUARD STORCART

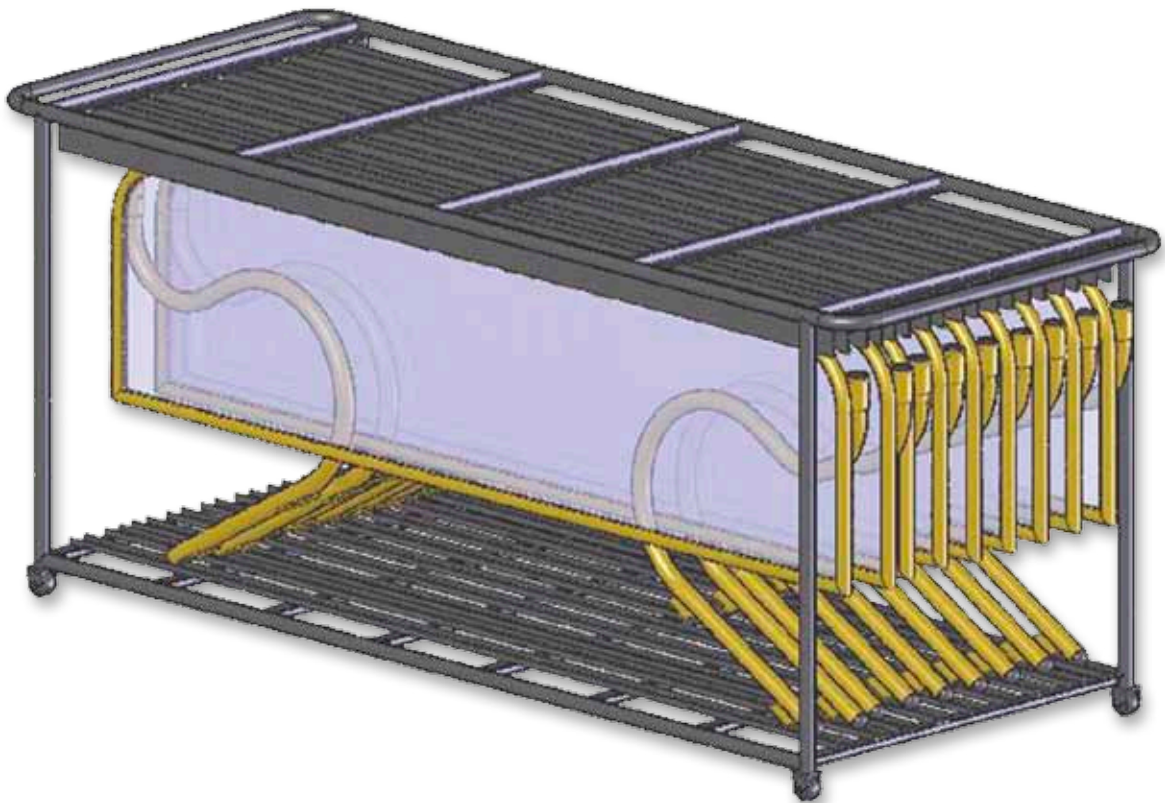
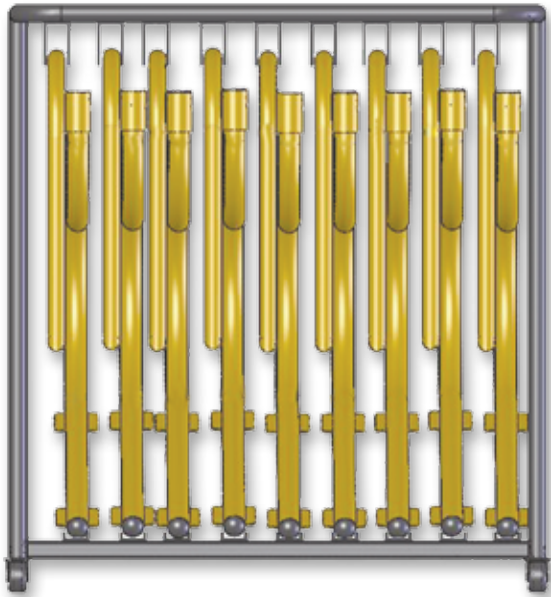

THE STORCART

* Images are computer renderings, not actual photos, some color variance may occur from what is rendered to the actual powder coat finish.

Phone: 800-569-2056
Fax: 573-449-7126
www.sneezeguardsolutions.com

SPECIFICATIONS

78" overall length

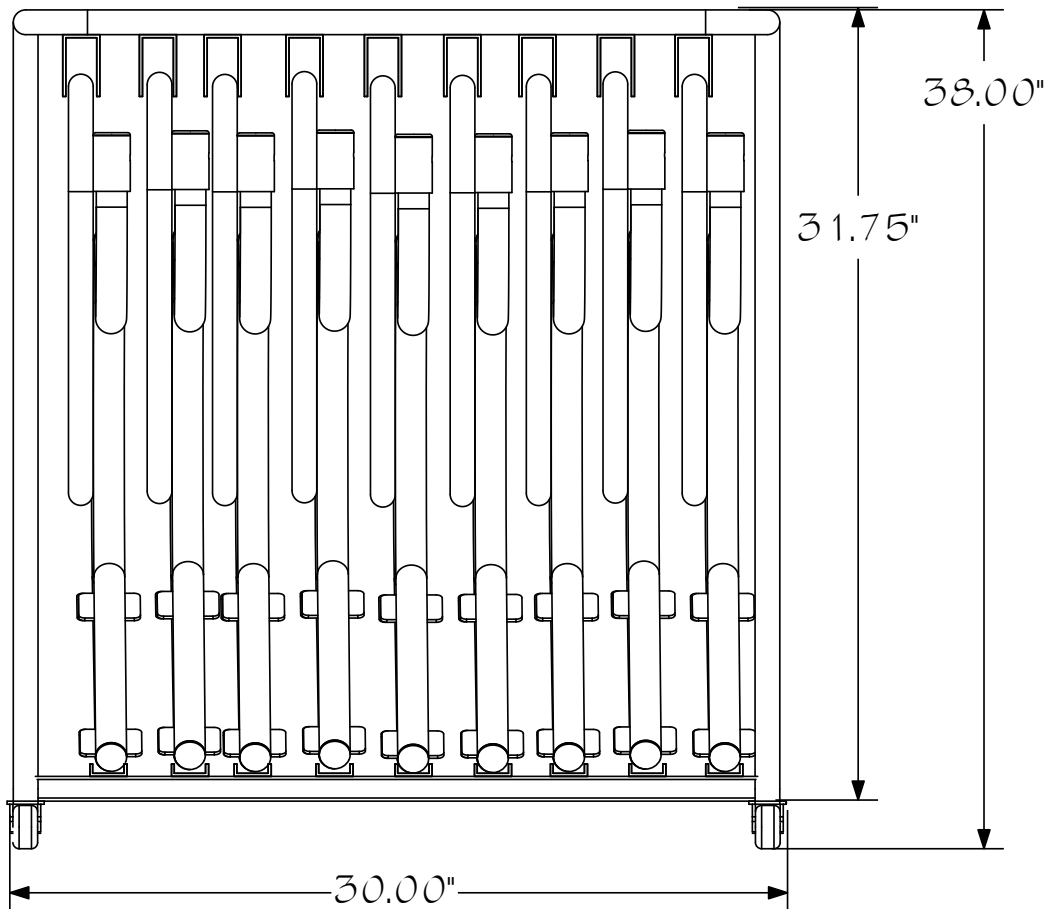

THE STORCART

* Shown with optional caster kit. Storcart height without caster kit is 31.75" inches overall

Model #	Length	Width	Height	Weight	Color
*1300	78"	30"	31.75" *	85 lbs	Black
**1450	78"	30"	38.00" *	105 lbs	Black
***1455	78"	30"	70.00" *	190 lbs	Black
****1330	N/A	N/A	4.00"	1 lbs	Black

* Model 1300 without casters.

* Add 4" for HP Model

** Model 1450 includes casters.

*** Model 1455 is a Double-Deck Storcart with casters.

**** Extension Kit for Hi-Profile guards.

*Caster Information (#1400):

- 5" diameter wheel.
- 2 with brakes, 2 with directional locks.
- Performa© wheel material (non-marking).
- NSF approved.

Phone: 800-569-2056

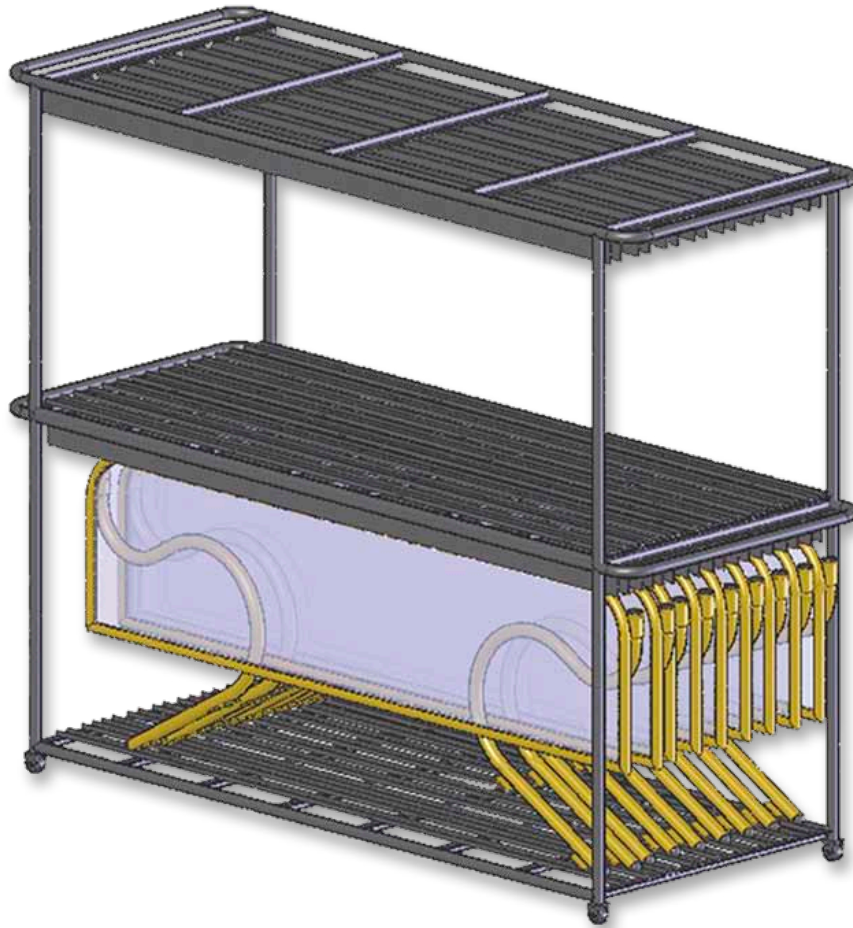

*Double Decker Model shown
18 Sneeze-guard capacity 70" Overall Height
HP Model 78" Overall Height*